

Automatic Rider Scrubbers

CT 110

29/32 Gallon, 28", 32"



TECHNICAL DATA		BT 70	BT 85
Scrubbing width	inch/mm.	28"/700mm	32"/850mm
Squeegee width	mm.	40"/1010mm	40"/1010mm
No. of brushes		2 (disc)	2 (disc)
Solution tank capacity	Gal/Ltr	29 Gal/110 Ltr	29 Gal/110 Ltr
Recovery tank capacity	l.	32 Gal/120 Ltr	32 Gal/120 Ltr
Battery power supply		24 V	24 V
		340 Ah	340 Ah
Empty weight without batt.	Lbs/kg		
Length	mm.	49"/1230mm	49"/1230mm
Width	mm.	30"/770mm	34"/870mm
Height	mm.	50"/1270mm	50"/1270mm



CT 110 High productivity (1)



Large tank capacity in minimum external space



29-32 Gal (110-115 Liter) capacity tanks make this model very unique in its category

Unique in its category with an 32" (85 cm) brush deck



Less time required to scrub surfaces



Extensive running time



Extremely large battery compartment allows batteries of up to 340 Ah (4 h continuous run time)

4 solution distribution options



STANDARD – Solution flow through basic adjustment

AUTOMATIC – Solution flow proportional upon machine speed

ECONOMY – Solution always at minimum adjustment

CHEM-DOSE (opt) – Automatic chemical dosage system

CT 110 High productivity (2)

CHEM-DOSE SYSTEM (optional)

The CHEM-DOSE system allows the use of chemicals separate from the clean water tank in order to optimise the machine in scrubbing effect and limit chemical consumption.

The system is controlled by a micro-processor that allows various use

- Chemicals dosage selection is adjustable from 1% to 10%
- The use of the selected dosage in **standard** solution flow setting
- The use of the selected dosage in **Automatic** solution flow setting
- The use of the selected dosage in **Economy** solution flow setting



1.3 Gal (5 Ltr) chemical tank can be installed under the operators seat

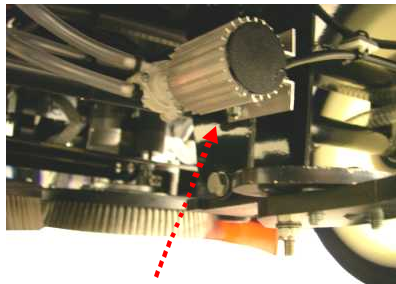

Special pump placed under the rear axle



The system is easy to program:

- 1) Press select button for 5 seconds to enter CHEM-DOSE
- 2) Select Cd 1 to cd 10 on display (1 = 1% / 2 = 2% etc) using + / - button
- 3) Choose solution flow required (standard – Automatic – Economy) with select button
- 4) You are ready to work and if you stop and turn on machine again the machine will keep memorised your last selection
- 5) If you want to exit CHE-DOSE just keep the select button pressed 5 seconds

CT 110 Great productivity (3)



Solution control with automatic stop



Saves water and save chemicals. Solution flow stops and starts upon traction pedal command.



Brush control with automatic delayed stop



Saves brush wear and protects floor surfaces. Brush rotation stops (4 sec delay) and starts upon traction pedal command.

Maximum speed setting adjustment

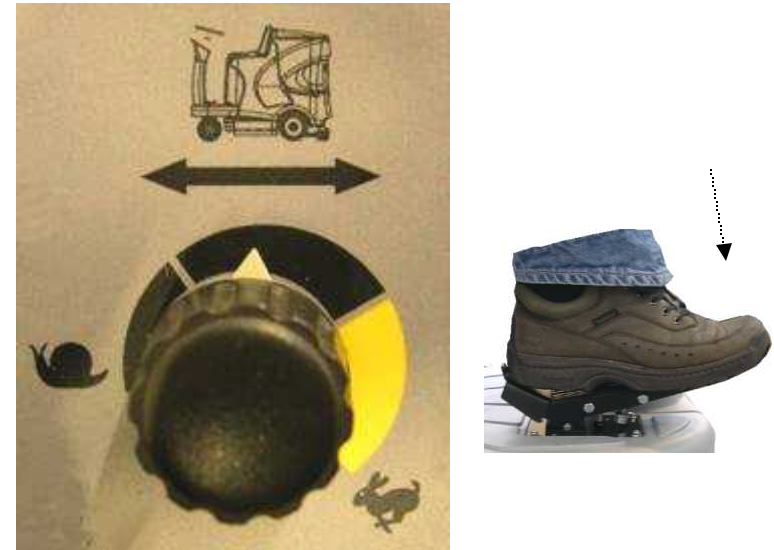

Potentiometer on dashboard allows the maximum speed setting to ensure best work productivity with less foot angle fatigue.

CT 110 High performance (1)



SLS (Self Levelling System)
Constant brush pressure control



Constant brush pressure with immediate spring reaction.
Avoids also excessive brush and actuator wear.



CFS (Center Flow System)



Central solution outlet on the brush ensures the entire use of the brush and does not waste water and detergent



High quality, high performance vacuum motor



Ametek 3 stage vacuum motor. Easily removed by 3 bolts and an electric quick disconnection plug.

Delayed 7 second vacuum switch off to allow vacuum of water left in hose between tank and squeegee.

Vacuum air outlet discharged under machine

CT 110 High performance (2)

Excellent water flow into tank



Dirty water shoots up directly from the squeegee, passes a curve made on the hood.

The passage slows the water that then falls into the tank in the furthest point the vacuum inlet is positioned.

Maximum vacuum seal in recovery tank



Limited gasket length (on lid) assures best vacuum sealing throughout the life of the machine

Short vacuum hose to gain maximum vacuum results from motor

47" (120 cm) length from squeegee to tank entrance



CT 110 High performance (3)



Exclusive squeegee system assures high performance at low cost



- A - V shape allows to collect all water whilst turning
- B – Distance between front and rear of squeegee is minimum allowing easy angle adjustment.
- C – Internal compartment height is low (less volume) and this allows to obtain better vacuum power.
- D – The width of the squeegee is exactly the same along its entire width allowing excellent drying results in every area.
- E – Minimum blade wear as the squeegee is kept up by 2 rear wheels
- F – Wheel height adjustment allows maximum blade wear life

Incomparable drying results even on the most difficult surfaces thanks to a very unique design.

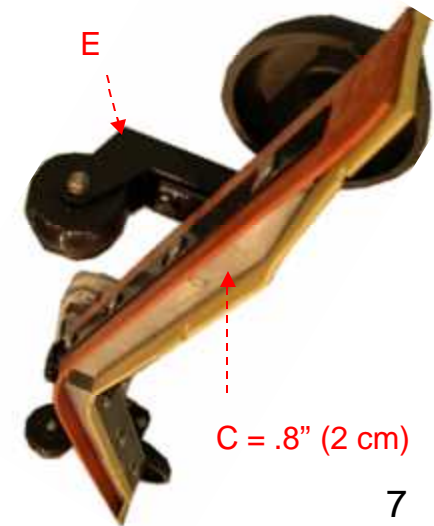
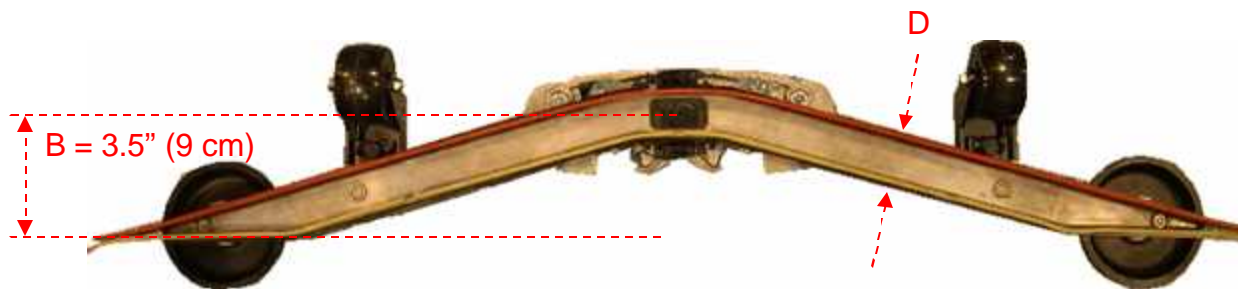

CT 110 Ergonomics, user friendly (1)



Great maneuverability due to optimum weight distribution



Easy to steer thanks to the design of the water tanks and battery compartment



Designed for maximum comfort



Comfortable seating, adjustable steering wheel and ergonomic traction pedal. Operator can step on machine from both sides



Great working visibility



Rounded front part of the machine and off set brush allows maximum working visibility

Ergonomic traction pedal

Reverse



Forward



Unique pedal for forward and reverse speed

CT 110 Ergonomics, user friendly (2)



Easy to use control panel



CT 110 Ergonomics, user friendly (3)



Solution and recovery tank level indicator

Right lamp indicates solution reserve and beeper warns that there is around 2 minutes solution left →



← Left lamp together with beeper indicates when recovery tank is full and vacuum fan is automatically switched off.



Battery level indicator

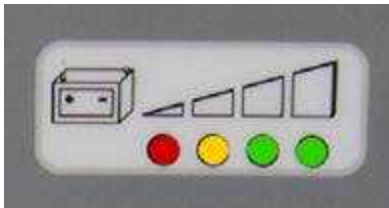

The battery is protected as follows:

Green = Sufficient charge

Yellow = (22,5V) Display indicates battery to be charged.

Red = (20,5V acid / 21,5V GI) All functions stop except traction

Red flashing = (18V) Machine stops also traction in order to protect battery



Automatic stop and start in working mode

Brushes
Solution
Vacuum
Traction



All functions stop and start upon traction pedal activation. Avoids having to stop and start the machine.



Designed to assure minimum noise levels



Insulated vacuum unit. 68 db(A) from 60" (1,5 m) distance

CT 110 Ergonomics, user friendly (4)



Large recovery tank discharge hose



2.5" (60 mm) diameter, 40" (1 m) length hose with flow adjustment system. Possible to discharge up to 16" (40 cm) height



Recovery tank can be tilted



Easy to rinse and clean with smooth internal finishes

Automatic slowing system while turning



Automatic slowing device assures maximum safety while turning even with traction pedal in maximum speed. Speed can be programmed. 60% maximum speed as standard.

Easy to understand compartments

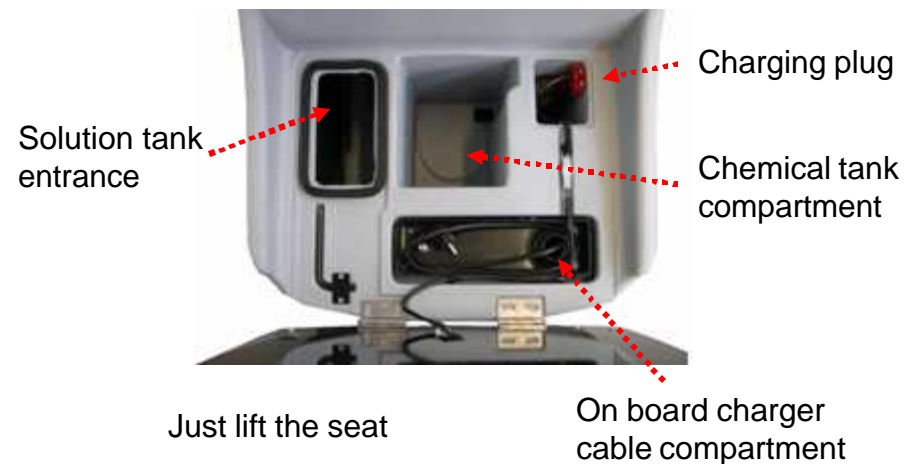

CT 110 Ergonomics, user friendly (5)



On-board charger can be installed now or later

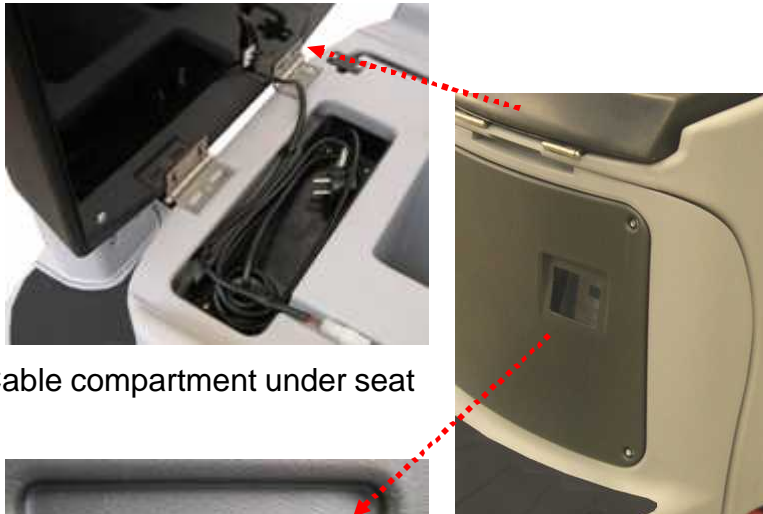

Cable compartment under seat



Acid or Gel charge selection switch

Equipped with digital display that indicates state of charging.



External battery charge plug



Just raise seat and plug is immediately reached. Once plug is inserted, machine is automatically cut off



Flashing beacon (optional)



Maximum visibility and safety

CT 110 Low maintenance costs (1)



Filter for maximum solution tank and circuit protection



Easy to reach and clean. Equipped with valve to close solution prior to valve



AFS (Anti Foam System)



Vacuum point positioned in the highest possible part of the machine.

Filter included for maximum vacuum motor protection

Sensor automatically turns off vacuum when recovery level is full



Brush replacement without tools



No tool, fully adjustable side skirts



Maximum skirt life is gained

CT 110 Low maintenance costs (2)



Automatic squeegee lift in reverse



Raises quick to avoid squeegee blade damage



Squeegee blade can be used on 4 sides before replacement



Maximum wear life is obtained



Squeegee assembly and blade replacement without tools



Both front and rear blades easily removable



Easy to reach components on Squeegee assembly

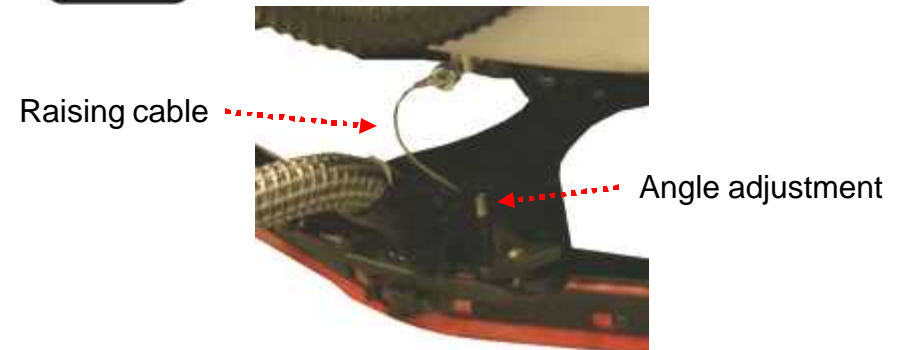

CT 110 Low maintenance costs (3)



Easy access to internal components



Unscrew bolt to tilt recovery tank sideways



3 bolts to remove vacuum fan



Squeegee hose removal without tools



Rear solution tank inspection



Simple to tilt entire tank body



Easy electro valve inspection

CT 110 Low maintenance costs (4)



Easy access to internal components



Battery tray removable without tools

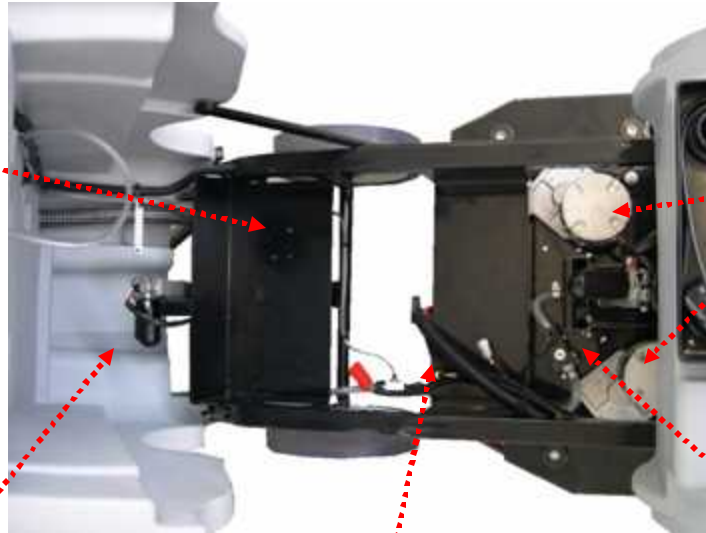

Brush motor carbon brushes replaced without tools



Easy to reach squeegee lifting actuator



All major electrical areas easily disconnected by water proof plugs

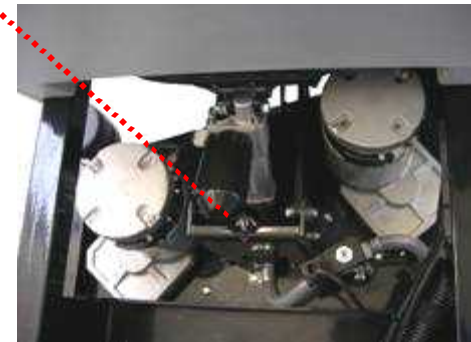

Brush head easy to dismantle

CT 110 Low maintenance costs (5)



Easy access to internal components



Clean and simple electric circuit that operates (through relay switches) all high amp functions on the machine.

Easy access fuses simply on the left hand side



Traction drive (Curtis) electronic card is separate from all other machine functions.

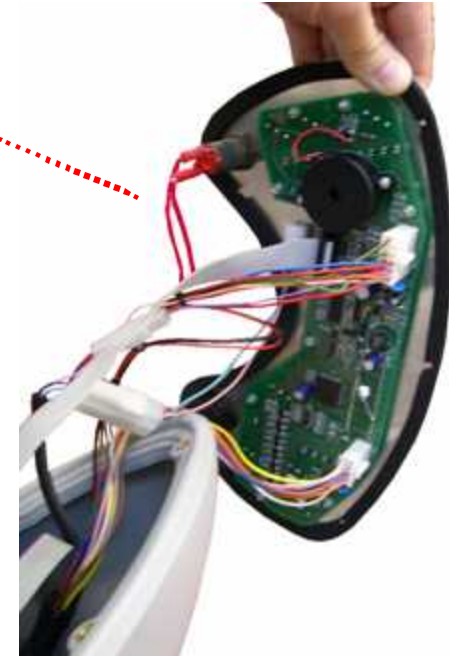

Electronic card operates only under low amp with draw to operate all automatic systems on the machine.

Dash board has extra length wiring to easily withdraw board from housing.

All compartments protected against water

CT 110 Low maintenance costs (6)



Easy access to internal components



No tool tank hood rubber replacement

Short hose passages with least bends as possible



Only bend on siphon, needed to avoid dripping when vacuum is turned off.

Easy to select battery type (Gel or Acid)



To select battery or Gel battery use as follows:

- 1) Turn on machine and stop it by means of emergency switch
- 2) Press both + / - switches for 5 seconds until setting appears on display (either **tIP.G** (Gel) or **tIP.A** (Acid)).
- 3) Choose type required with select button
- 4) Disconnect emergency switch to exit program

CT 110 Robust construction (1)



Tanks and surrounding body in high density polyethylene



Thick material moldings



Brush head designed to absorb harsh impact



Large 4" (10 cm) roller wheels for maximum protection



Oil bath reduction gear box

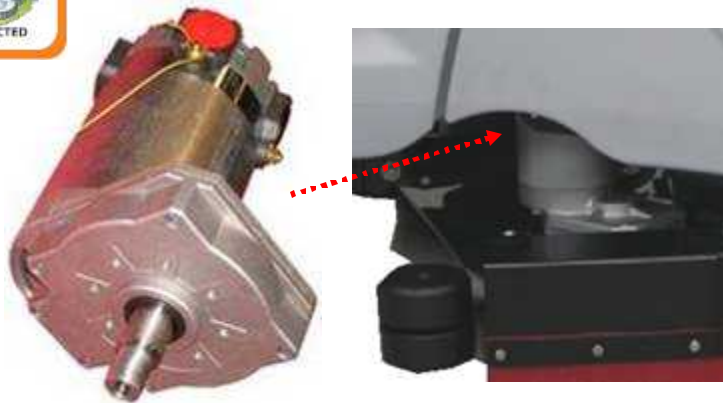

Large diameter gears for less motor fatigue



Squeegee system designed to absorb harsh impact



Maximum squeegee support movement and large 4" (10 cm) rollers for maximum squeegee protection

CT 40 Robust construction (2)

Heavy duty front traction wheel with electro brake incorporated

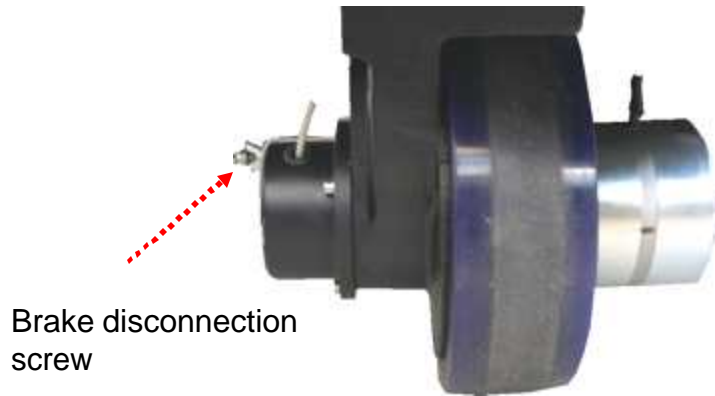

Large wheels

Front



Rear



8" (20 cm) and 10" (25 cm) diameter non marking wheels



Panel control switches protected against water and humidity

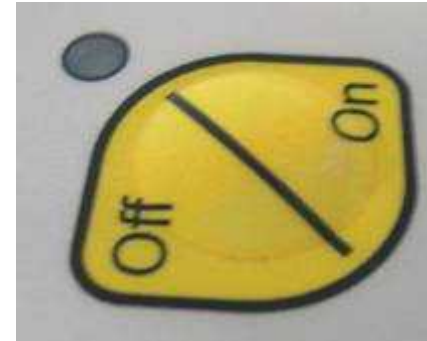

Clean Solution tank discharge



Just open, drain and vacuum into squeegee for easy removal

CT 110 Available accessories

All accessories are supplied as spares separately from standard unit



On board battery charger



Higher rollers for squeegee impact protection



Chem Dose system

Aggressive oil rubber kit



Flashing beacon